



C500 Series

Hygienic leveling feet

Movex[®]

www.movexii.com

C500

Hygienic & Certified



Hygienic Design

Completely sanitized and certified.



Superior Durability

Thanks to the threaded part's cover.



Saving (Energy, water, detergents)

Fewer resources and time for sanitation.



Cleanliness

Reduced washing cycle.



Food contact Certified

C500 series design is suitable in food application.



Certified product

C500 series is certified 3A and EHEDG.

The best choice for hygienic environments!

Specifically designed for industrial environments with critical hygienic level, **Movex®** leveling feet are the perfect solutions for dairy, food, chemical and pharmaceutical industries, subjected to daily washing cycles.

The **C500 series** offers a complete protection against bacterial proliferation and guarantees reduced washing cycle time as well as self-draining surfaces able to drain external elements easier than traditional systems.

Baseplate, spindle and cover are produced exclusively in AISI 304, with surface finishing lower than 0,8 μm , silicon blue seals are **FDA approved** and easily detectable by industrial scanner.



Description and Features



Silicon blue seal positioned at the end of the cover to seal the threaded part

Silicon blue seal inside the cover to seal the spindle

Certified nut with blue seals to fix the leveling foot to the floor

Vulcanized NBR anti-slip rubber to guarantee hermetic closure between the leveler and the floor

Metric thread standard pitch (available fine pitch or imperial)

Stainless steel cover to protect threaded spindle

Silicon blue seal to guarantee spindle and base closure

Stainless steel base in AISI 304 with self-draining surface to reduce washing time



Available range

C500 Series
For standard applications

C500 Series SPLIT
For application with higher floor slope or where separate base and spindle is required

C500 Series HEAVY
For high load applications

C500 Series HEAVY-SPLIT
For high load applications where the separate base and spindle is required

General products features

Baseplate diameters	Ø60÷Ø150 mm
Spindle threads	M12÷M36
Maximum load	4.500÷150.000 N
Max tensile strength	4.000÷8.000 N
Total heights	182,5÷305 mm
Adjustment heights	45÷65 mm

Every leveling foot baseplate is marked with proper certification logo

Material description:

- Feet baseplates in AISI 304
- Spindles and covers in AISI 304
- Blu seals for hermetic closure
- Vulcanized anti-slip rubber

Provided documentation

- Official hygienic certifications
- Installation instruction
- Maintenance and cleaning instructions
- Material declaration of conformity (available in the catalogue)

Product range



C500
STANDARD

Available Ø
60 | 80 | 105 | 125 | 150

Height variation 105-270 mm
Load up to 45.000 N

Blue seals for hermetic closure
Reduced roughness



C500
SPLIT

Available Ø
60 | 80 | 105 | 125 | 150

Height variation 105-270 mm
Load up to 45.000 N
Floor inclination up to 12°

Blue seals for hermetic closure
Reduced roughness



C500
HEAVY

Available Ø
60 | 80 | 105 | 125 | 150

Height variation 102.5-259.5 mm
Load up to 150.000 N

Blue seals for hermetic closure
Reduced roughness



C500
HEAVY-SPLIT

Available Ø
60 | 80 | 105 | 125 | 150

Height variation 102.5-259.5 mm
Load up to 150.000 N
Floor inclination up to 12°

Blue seals for hermetic closure
Reduced roughness

*Please find out all related information and article numbers on our leveling feet catalogue, visit our web site or ask directly to your sales representative.

Selection guide

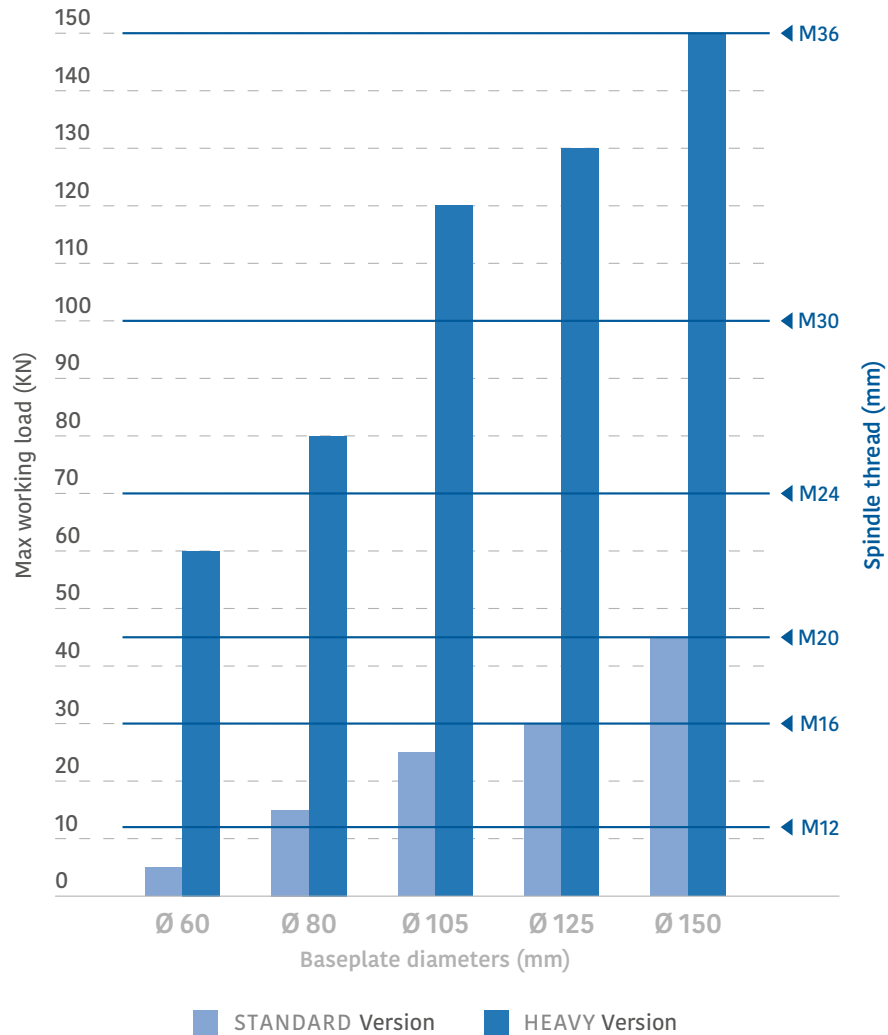

Accessories

Top cover

HYGIENIC AND CERTIFIED

304
AISI



Main features:

- Blue seal for hermetic closure
- Perfect to protect the thread spindle
- Available from M12 to M36

Hygienic nut

HYGIENIC AND CERTIFIED

304
AISI



Main features:

- Blue seal for hermetic closure
- Available from M6 to M20

Replacement of original components and accessories with others of a type not approved by Movex, doesn't allow the high hygienic standard and makes product certification invalid.

C500 STANDARD

HYGIENIC AND CERTIFIED STAINLESS STEEL LEVELER

Main features:

- Overmolded self-draining baseplate in AISI 304 stainless steel
- Spindle and cover in AISI 304 stainless steel
- Blue seals for hermetic closure
- Vulcanized anti-slip NBR rubber

Leveling feet Ø 80 mm

Art-Nr.	Sp	H Tot (mm)	H Min (mm)	H Max (mm)	A (mm)	1 (mm)	2 (mm)	Load (N)
902839	M16	190	110	155	45	13	19	15.000
902840		240	140	205	65	13	19	
902841	M20	190	110	155	45	17	24	15.000
902842		240	140	205	65	17	24	
902843	M24	190	110	155	45	19	30	15.000
902844		240	140	205	65	19	30	

Other threads available: M12 | M30 | M36

Leveling feet Ø 125 mm

Art-Nr.	Sp	H Tot (mm)	H Min (mm)	H Max (mm)	A (mm)	1 (mm)	2 (mm)	Load (N)
902867	M16	195	115	160	45	13	19	30.000
902868		245	145	210	65	13	19	
902869	M20	195	115	160	45	17	24	30.000
902870		245	145	210	65	17	24	
902871	M24	195	115	160	45	19	30	30.000
902872		245	145	210	65	19	30	

Other threads available: M12 | M30 | M36

Other diameters available: 60 | 105 | 150 mm

* Please find out all related information and article numbers on our leveling feet catalogue, visit our web site or ask directly to your sales representative.

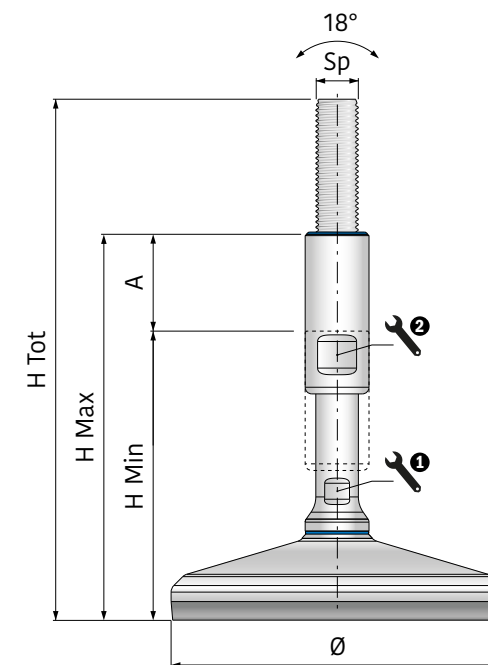

304
AISI

CERTIFIED PRODUCT



ASK FOR CERTIFICATION:
certificate@movexii.com

The C500 series, with overmolded baseplate in AISI 304 stainless steel, threaded spindle with cover and hermetic seals is the best choice for industrial environments with critical hygienic level, like dairy, food, chemical and pharmaceutical industries, subjected to daily washing cycles.

The stainless steel baseplate and its particular shape guarantee an excellent cleanability, especially in critical conditions; the stainless steel cover offers 100% thread protection and avoids its exposure to external agents; the three seals (blue silicone detectable with food scanner) placed respectively inside the cover and between the spindle and the baseplate guarantee a hermetic closure, avoiding any external parts infiltration and the NBR rubber guarantees anti-slip proprieties and hermetic closure between the leveller and the floor.

Maximum compressive strength (static load) as in the table, maximum tensile strength (static load) 4.000 N

C500 SPLIT

HYGIENIC AND CERTIFIED STAINLESS STEEL LEVELER

Main features:

- Overmolded self-draining baseplate in AISI 304 stainless steel
- Spindle and cover in AISI 304 stainless steel
- Blue seals for hermetic closure
- Vulcanized anti-slip NBR rubber
- Separate spindle and baseplate

Leveling feet Ø 80 mm

Art-Nr.	Sp	H Tot (mm)	H Min (mm)	H Max (mm)	A (mm)	1 (mm)	2 (mm)	Load (N)
902965	M16	190	110	155	45	13	19	15.000
902966		240	140	205	65	13	19	
902967	M20	190	110	155	45	17	24	15.000
902968		240	140	205	65	17	24	
902969	M24	190	110	155	45	19	30	15.000
902970		240	140	205	65	19	30	

Other threads available: M12 | M30 | M36

Leveling feet Ø 125 mm

Art-Nr.	Sp	H Tot (mm)	H Min (mm)	H Max (mm)	A (mm)	1 (mm)	2 (mm)	Load (N)
902993	M16	195	115	160	45	13	19	30.000
902994		245	145	210	65	13	19	
902995	M20	195	115	160	45	17	24	30.000
902996		245	145	210	65	17	24	
902997	M24	195	115	160	45	19	30	30.000
902998		245	145	210	65	19	30	

Other threads available: M12 | M30 | M36

Other diameters available: 60 | 105 | 150 mm

* Please find out all related information and article numbers on our leveling feet catalogue, visit our web site or ask directly to your sales representative.

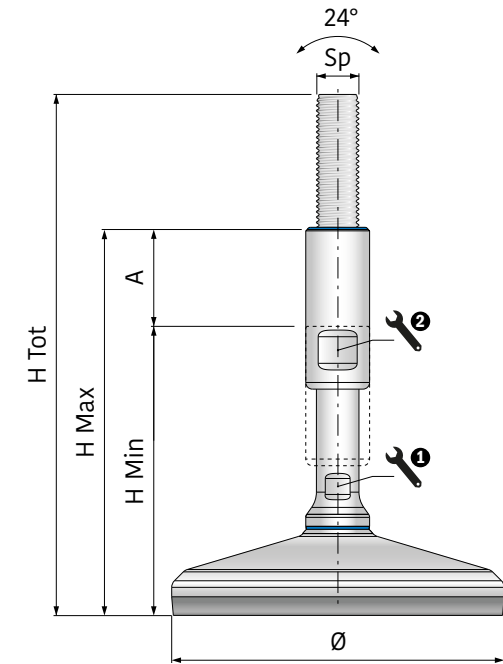

304
AISI



The C500-SPLIT series, with overmolded baseplate in AISI 304 stainless steel, separate threaded spindle with cover and hermetic seals is the best choice for industrial environments with critical hygienic level, like dairy, food, chemical and pharmaceutical industries, subjected to daily washing cycles.

The stainless steel baseplate and its particular shape guarantee an excellent cleanability, especially in critical conditions; the stainless steel cover offers 100% thread protection and avoids its exposure to external agents; the three seals (blue silicone detectable with food scanner) placed respectively inside the cover and between the spindle and the baseplate guarantee a hermetic closure, avoiding any external parts infiltration and the NBR rubber guarantees anti-slip properties and hermetic closure between the leveller and the floor.

Maximum compressive strength (static load) as in the table, maximum tensile strength (static load) not available because the baseplate and the spindle are separate.

C500 HEAVY

HYGIENIC AND CERTIFIED STAINLESS STEEL LEVELER

304
AISI

Main features:

- Full machined self-draining baseplate in AISI 304 stainless steel
- Spindle and cover in AISI 304 stainless steel
- Blue seals for hermetic closure
- Vulcanized anti-slip NBR rubber

Leveling feet Ø 80 mm

Art-Nr.	Sp	H Tot (mm)	H Min (mm)	H Max (mm)	A (mm)	1 (mm)	2 (mm)	Load (N)
903105	M16	183,5	103,5	148,5	45	13	19	30.000
903106		233,5	133,5	198,5	65	13	19	
903107	M20	183,5	103,5	148,5	45	17	24	45.000
903108		233,5	133,5	198,5	65	17	24	
903109	M24	183,5	103,5	148,5	45	19	30	70.000
903110		233,5	133,5	198,5	65	19	30	

Other threads available: M12 | M30 | M36

Leveling feet Ø 125 mm

Art-Nr.	Sp	H Tot (mm)	H Min (mm)	H Max (mm)	A (mm)	1 (mm)	2 (mm)	Load (N)
903133	M16	184,5	104,5	149,5	45	13	19	30.000
903134		234,5	134,5	199,5	65	13	19	
903135	M20	184,5	104,5	149,5	45	17	24	45.000
903136		234,5	134,5	199,5	65	17	24	
903137	M24	184,5	104,5	149,5	45	19	30	70.000
903138		234,5	134,5	199,5	65	19	30	

Other threads available: M12 | M30 | M36

Other diameters available: 60 | 105 | 150 mm

* Please find out all related information and article numbers on our leveling feet catalogue, visit our web site or ask directly to your sales representative.



Nut
Hygienic and certified

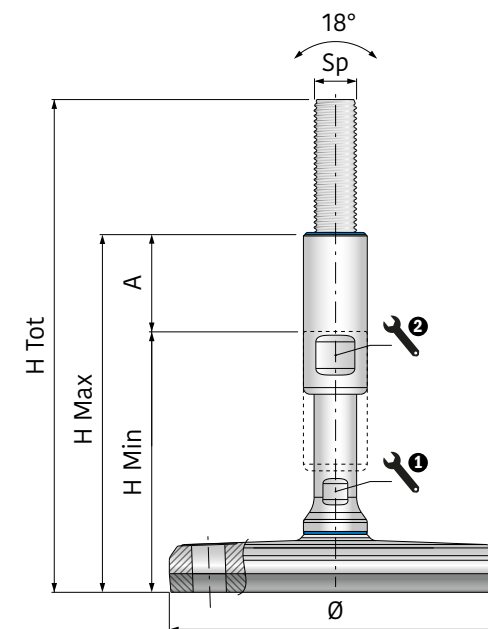

CERTIFIED PRODUCT

ASK FOR CERTIFICATION:
certificate@movexii.com

Nut - Hygienic and certified

Art-Nr.	Sp	Hole Ø	Version
903236	M8	8.5	for Ø 80
903237	M10	13	for Ø 125

The C500-HEAVY series, with full machined baseplate in AISI 304 stainless steel, threaded spindle with cover and hermetic seals is the best choice for industrial environments with critical hygienic level, like dairy, food, chemical and pharmaceutical industries, subjected to daily washing cycles.

The stainless steel baseplate and its particular shape guarantee high load resistance and an excellent cleanability, especially in critical conditions; the stainless steel cover offers 100% thread protection and avoids its exposure to external agents; the three seals (blue silicone detectable with food scanner) placed respectively inside the cover and between the spindle and the baseplate guarantee a hermetic closure, avoiding any external parts infiltration and the NBR rubber guarantees anti-slip properties and hermetic closure between the leveler and the floor.

Maximum compressive strength (static load) as in the table, maximum tensile strength (static load) 8.000 N

C500 HEAVY-SPLIT

HYGIENIC AND CERTIFIED STAINLESS STEEL LEVELER

Main features:

- Full machined self-draining baseplate in AISI 304 stainless steel
- Spindle and cover in AISI 304 stainless steel
- Blue seals for hermetic closure
- Vulcanized anti-slip NBR rubber
- Separate spindle and baseplate

304
AISI

Leveling feet Ø 80 mm

Art-Nr.	Sp	H Tot (mm)	H Min (mm)	H Max (mm)	A (mm)	1 (mm)	2 (mm)	Load (N)
903175	M16	183,5	103,5	148,5	45	13	19	30.000
903176		233,5	133,5	198,5	65	13	19	
903177	M20	183,5	103,5	148,5	45	17	24	45.000
903178		233,5	133,5	198,5	65	17	24	
903179	M24	183,5	103,5	148,5	45	19	30	70.000
903180		233,5	133,5	198,5	65	19	30	

Other threads available: M12 | M30 | M36

Leveling feet Ø 125 mm

Art-Nr.	Sp	H Tot (mm)	H Min (mm)	H Max (mm)	A (mm)	1 (mm)	2 (mm)	Load (N)
903203	M16	184,5	104,5	149,5	45	13	19	30.000
903204		234,5	134,5	199,5	65	13	19	
903205	M20	184,5	104,5	149,5	45	17	24	45.000
903206		234,5	134,5	199,5	65	17	24	
903207	M24	184,5	104,5	149,5	45	19	30	70.000
903208		234,5	134,5	199,5	65	19	30	

Other threads available: M12 | M30 | M36

Other diameters available: 60 | 105 | 150 mm

* Please find out all related information and article numbers on our leveling feet catalogue, visit our web site or ask directly to your sales representative.

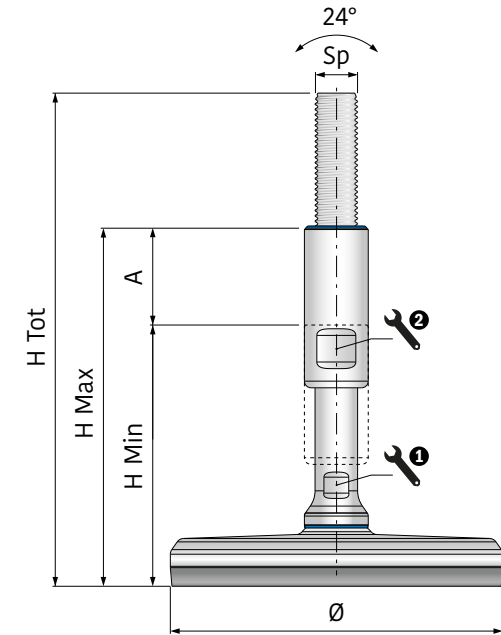

The C500-HEAVY-SPLIT series, with full machined baseplate in AISI 304 stainless steel, separate threaded spindle with cover and hermetic seals is the best choice for industrial environments with critical hygienic level, like dairy, food, chemical and pharmaceutical industries, subjected to daily washing cycles.

The stainless steel baseplate and its particular shape guarantee high load resistance and an excellent cleanability, especially in critical conditions; the stainless steel cover offers 100% thread protection and avoids its exposure to external agents; the three seals (blue silicone detectable with food scanner) placed respectively inside the cover and between the spindle and the baseplate guarantee a hermetic closure, avoiding any external parts infiltration and the NBR rubber guarantees anti-slip properties and hermetic closure between the leveler and the floor.

Maximum compressive strength (static load) as in the table, maximum tensile strength (static load) not available because the baseplate and the spindle are separate.

Higher hygienic standards

In sensitive areas like food processing and pharmaceutical production, an high level of hygienic standard is an essential element to reduce the risk of contamination, therefore it's important to use certified products in order to protect the production and the surrounding environment.

The **C500 series** has 3A and EHEDG certifications which are released by no profit associations that protect consumers, guaranteeing products made according to the internal standards.

This applies to all processes and components in contact directly or indirectly with every single food.

Movex is committed to offer a high quality product in according to the most recent normative.

Why choose a certified product?



Certified Hygienic



Lower Cleaning



Lower resources Consumption

What are 3A and EHEDG certification?



- Non-profit American association
- Regulations for food manufacturers, machine food manufactures and food raw material suppliers
- Public and governmental health agencies
- Over 70 guidelines

Comparison between stainless steel leveler with fully threaded spindle and hygienic and certified leveler

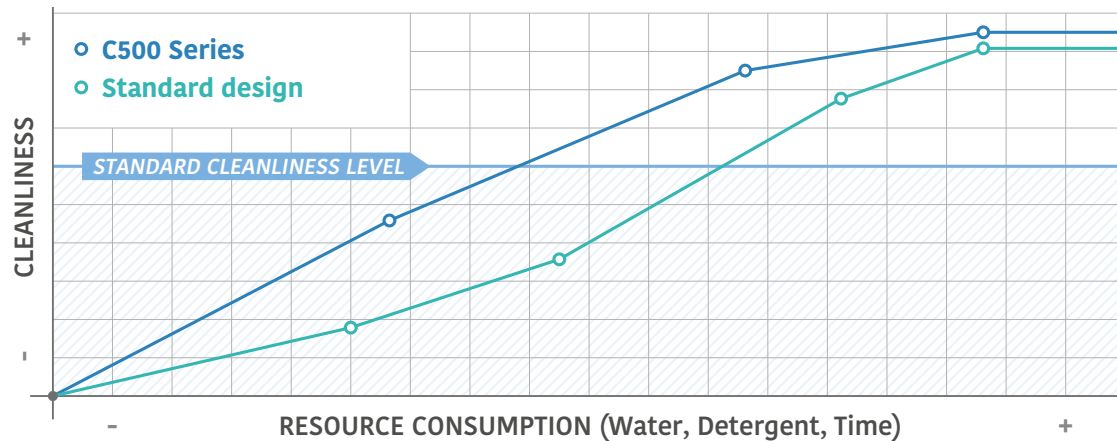

- Non-profit European consortium
- Regulations for food manufacturers, machine food manufactures and food raw material suppliers
- Research institutes and universities
 - Government health agencies
- Approximately 45 guidelines

Guaranteed and certified solution



Provided with 3A and EHEDG certifications, the **C500 leveling feet series** is approved by most recent normative and satisfies hygienic environment guidelines.

Being the cleaning process one of the most effective part of the sanitation, Movex products help reducing time required for maintenance and, at the same time, provide engineered shapes and surface finishing to improve self-draining proprieties.

The complete closed design avoids bacterial proliferation and guarantees maximum cleanliness.

Seals and vulcanized rubber, compliant to FDA, ROHS and REACH normative, make the feet dust-tight and powerful high-temperature water jets resistant and long lasting.

Ref. Norms.



Main steps required to sanitize a stainless steel C500 leveling foot

For the complete process please check on our catalogue or visit our website



Identify dirt leveler



Rinse with water
(max 40°C)

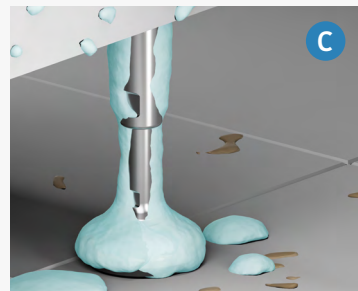

Apply detergent and let it act
(min 10 mins)



Rinse with high-press
(max 40°C)

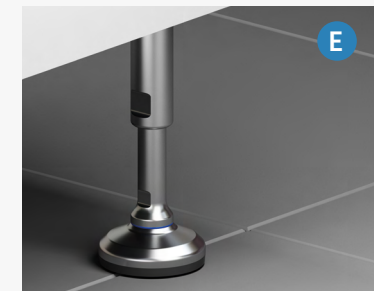

The foot is now cleaned!

Movex[®]

Movex worldwide

Movex GmbH

P +49-6204-9375-0

Movex Brasil Ltda

P +55-15-3141-2550

Movex France

P +33-06-21-02-79-15

Movex AG India

P +91-120-4159660-62

Movex UK Ltd.

P +44-77-20678442

Movex Nederland

P +31-630-994850

Movex USA Inc.

P +1-877-401-5377

Movexii SA de CV

P +52-1-3318458187

Movex CIS Countries

P +39-348-7769760

Movex S.p.A.

Headquarters

Viale Industria, 22 - 24060
Castelli Calepio (BG) Italy

Logistics center

Via Repubblica, 21/E - 24060
Castelli Calepio (BG) Italy

P +39 035 8359711 | F +39 035 4420873 | info@movexii.com | www.movexii.com

Follow us   

